

SV-LED70WP4 / SV-690H-KIT DAY/NIGHT COLLISION AVOIDANCE SYSTEM



**SV-LED70WP4
(Monitor)**



**SV-690H-KIT color camera
(Interior or Exterior)**



**SV-CCKO camera cage and SV-LCD-RM10-4 RAM mount
(optional mounting solutions for camera and monitor)**

The SV-LED70WP4 is a rugged, 7" video monitor designed to withstand the demanding shock and vibration requirements of in-vehicle monitoring. In addition to its high impact rating, the SV-LED70WP4 is IP68 rated to protect your investment against dust, water and other environmental contaminants. The high contrast screen includes an integrated control box with multiple display options, auto day/night switching, parking distance markers and more to establish the SV-LED70WP4 as the ideal monitoring solution for fleet vehicles.

When the vehicle starts or is placed in reverse, the system activates. With the camera's built-in microphone, people behind the vehicle can communicate directly with you alerting you to possible hazards.

The SV-690H camera sets a new standard in imaging and ruggedness for on-board camera systems. The SV-690H utilizes the latest SuperHADII sensor to provide sharp, clear images while minimizing smear and blooming artifacts. The ultra wide angle 115° field of view combined with built-in IR illumination ensures maximum coverage even in complete darkness. And with an environmental rating of IP69K, the SV-690H is built to withstand the harshest environmental conditions for years of reliable, dependable service.

SPECIFICATIONS

SV-LED70WP4 Monitor

LCD System	7-inch
Video System	NTSC/PAL
Display Mode	Single/Split/Triple/PIP/Quad
OSD Controls	Day/Night Sensor, Bright, Contrast, Color, Tint, Mirror/Normal, Day/Night Mode, Scale
Aspect Ratio	16:9
Resolution	800 (H) x 480 (V)
Impact Rating	7G
I.P. Factor	IP 68
Power Requirement	10 - 32 VDC
Power Consumption	30W Maximum
Operating Temperature	-22°F ~ 167°F (-30°C ~ 75°C)
Dimensions (w x h x d)	7.6 in. x 4.8 in. x 1.2 in. (194 mm x 124 mm x 31.5 mm)
Weight	1.6 lb. (0.72 kg)

SPECIFICATIONS

SV-690H-KIT Camera

Image Sensor	Sony Super HAD II CCD
Picture Element	NTSC: 410,000 pixels PAL: 470,000 pixels
Image Size	1/3 Inch
Lens	Horizontal : 115° Vertical: 83°
Synchronization	Internal
Min. Illumination	0 Lux W/ IR LED
Signal To Noise Ratio	> Better than 50dB (AGC off)
Power Supply	DC 12V
Power Consumption	3.0W
Vibration	10G
Impact	100G
IP Factor	IP 69K
Operating Temperature	-22°F ~ 176°F (-30°C ~ 80°C)
Case Material	Aluminum Diecast
Weight	0.46 lbs (210 g)

SV-LED70WP4 / SV-690H-KIT DAY/NIGHT COLLISION AVOIDANCE SYSTEM

SV-LED70WP4 DIMENSIONS

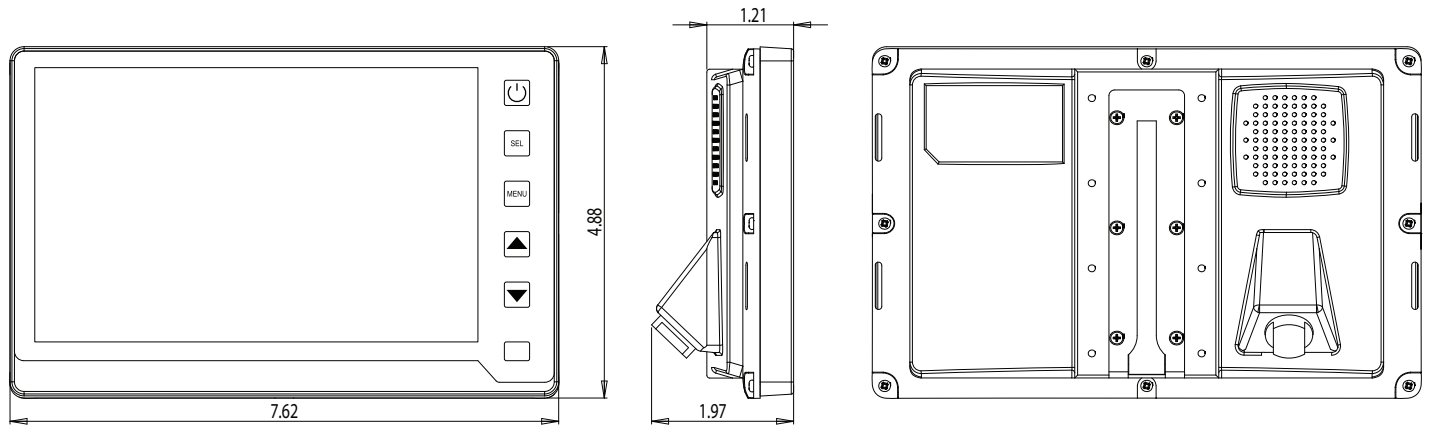

SV-690H-KIT DIMENSIONS

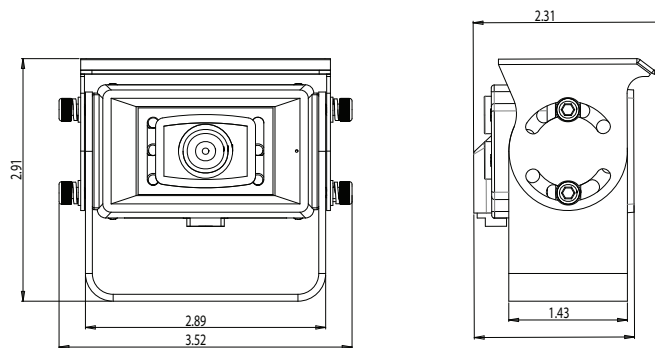

SV-LCD-RM10-4 DIMENSIONS

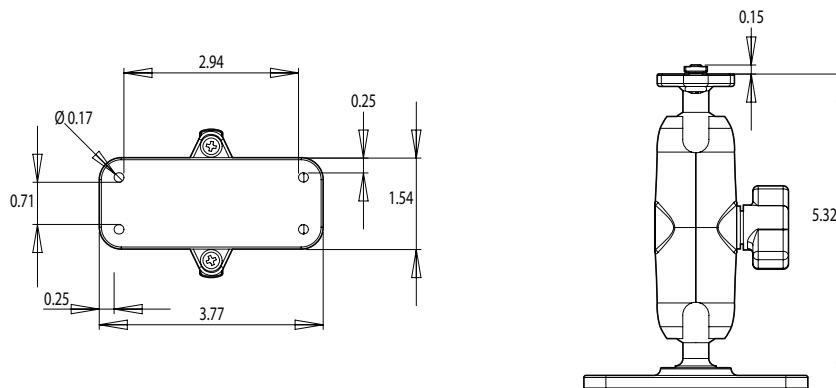

Warranty Agreement

Safety Vision's standard warranty for new items is one year. Extended warranties and advance replacement agreements also are available. Ask your sales or customer service representative for details.

6100 W. Sam Houston Pkwy. N.

Houston, TX 77041-5113

Main: 713.896.6600 | Toll Free: 800.880.8855 | Fax: 713.896.6640